



# 慈溪市萬捷電子有限公司

## CIXI WANJIE ELECTRONIC CO., LTD

### 产品规格书

product specification

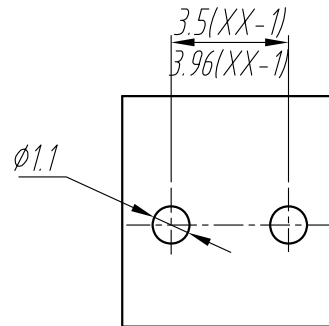
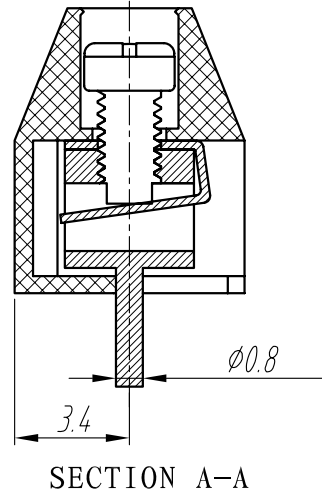
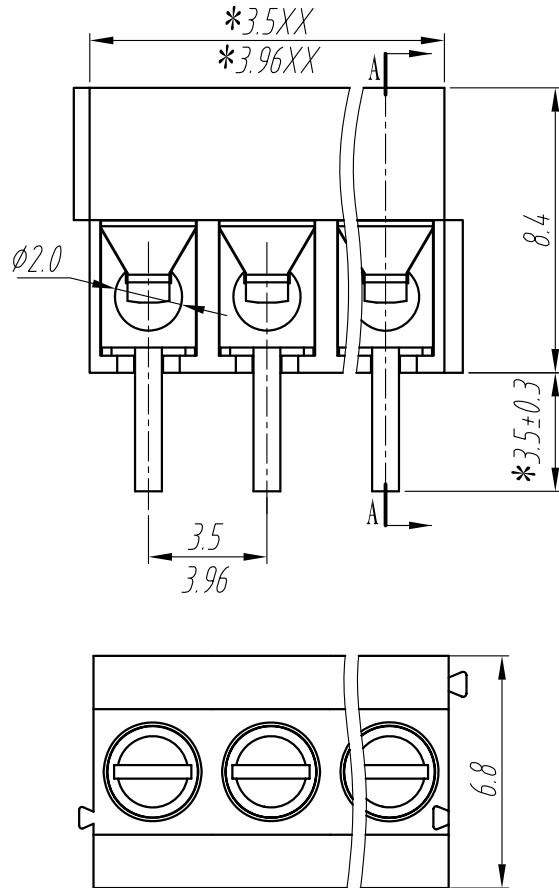

### 电气性能/Electrical

参考标准/Standard	UL	IEC
额定电压/Rated voltage	125V	130V
额定电流/Rated current	10A	10A
接触电阻/Contact resistance	20mΩ	
绝缘电阻/Insulation resistance	5000MΩ/DC1000V	
使用线径/Wire range	24-18AWG 1.0mm <sup>2</sup>	
耐电压/Withstanding voltage	AC 2000V/1 Min	

### 机械性能/Mechanical

温度范围/Temp.Range	-40℃~+105℃
瞬时温度/MAX Soldering	+250℃ for 5 Sec
扭矩/Torque	0.2Nm(1.7lb.in)
剥线长度/Strip length	4.5-5mm

### 尺寸/Dimensions

间距/Pitch	3.5mm, 3.96mm
极数/Poles	2p. xxp

### 材质及电镀/Material

塑件/Housing	PA66,UL94V-0
螺丝/Screws	M2 steel Zinc plated
焊针/Pin housing	Brass, Tin plated
簧片/Wire guard	Phosphor bronze, Ni plated

#### TOLERANCES EXCEPT AS NOTED

	linear dimension				fillet	chamfer	short angle sid				≡	—	□	//	⊥	
	over	over	over	over			over	over	over	over						
variable range	to 6	to 30	to 120	to 480	all	to 6	to 10	to 50	to 120	all	to 5	to 30	to 120	to		
tolerance	±0.1	±0.2	±0.3	±0.5	±0.2	±0.5	±1	1°	30'	20'	10'	0.5	0.025	0.06	0.12	0.4

单位/UNITS mm 尺寸/SIZE A4 比例/SCALE

第一视角/FIRST ANGLE PROJECTION

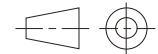

慈溪市萬捷電子有限公司  
CIXI WANJIE ELECTRONIC CO., LTD

名称/NAME

WJ350-3.50  
WJ396-3.96